

DWG. NO. G610-04-A-1_REF

ALL DIMENSION ARE IN INCHES (mm) AND FOR REFERENCE ONLY

ZINC PLATED LOCKNUT
ASSEMBLY TORQUE
60 IN-LB (6.8 N-m)
TYP 2 PLCS

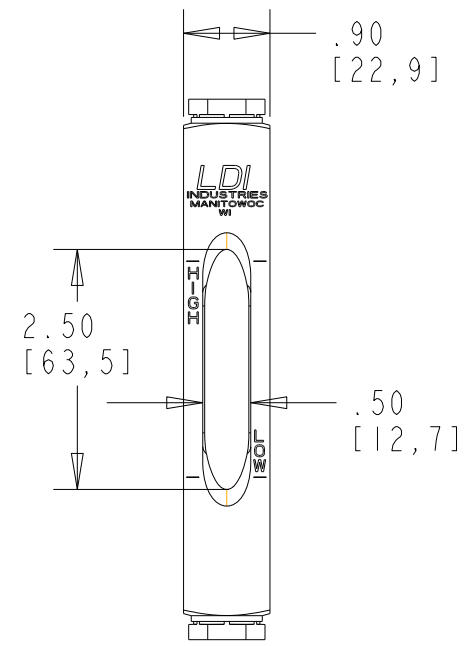
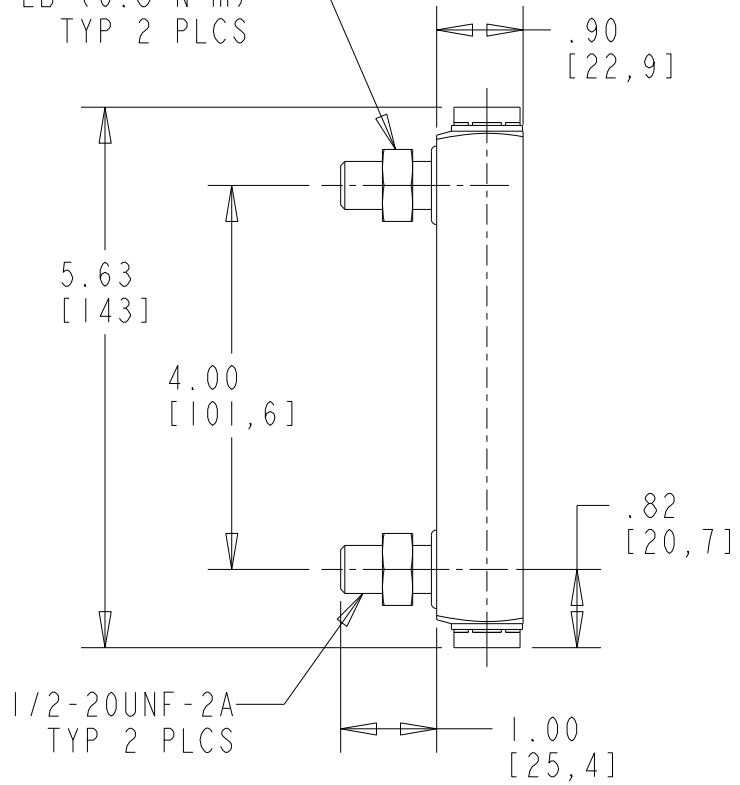

NOTES:

1. ALUMINUM CONSTRUCTION
2. BUNA N SEALS
3. BOROSILICATE GLASS WITH REDLINE ON WHITE BACKGROUND
4. 250°F (121.1°C) MAX TEMPERATURE
5. 290 PSI (2.0 MPa) MAX PRESSURE @150°F (65.6°C) AND NO CORROSION

MATL	SEE NOTES
MATL ITEM NO	-
MATL DESC	-
FINISH	NONE
CUST NO	-
SIMILAR TO	-
NOM WT (LBS.)	0.441
RFQ NO	-

TOLERANCES
UNLESS OTHERWISE SPECIFIED

.XX ±
.XXX ±

ALL RADII:
ANGLES ±
SURFACE FIN.
BRK CORNERS

THIS DOCUMENT CONTAINS INFORMATION PROPRIETARY TO LDI Industries, Inc. AND IS FURNISHED UPON THE EXPRESS CONDITION THAT THE INFORMATION CONTAINED HEREIN WILL NOT BE DISCLOSED TO ANY THIRD PARTY OR USED DIRECTLY OR INDIRECTLY IN ANY WAY DETRIMENTAL TO THE INTEREST OF LDI Industries, Inc.



TITLE **GAGE_BMNT_4.00_AL_F_NBR**

DWG NO./ITEM NO. **G610-04-A-1_REF**

REV	DATE	ECN NO.	BY
-	-	-	-

SCALE	1/2	DO NOT SCALE DRAWING	DRWN DMP	DATE	8/7/12	CHKD DMP	DATE	8/7/12	SHT 1/1	REV -
-------	-----	----------------------	----------	------	--------	----------	------	--------	---------	-------